

Algebra 1 Mastery Test #9 Review**Solve the system:**

1. $x + 4y = 13$

$-x + y = 2$

2. Rewrite using only positive exponents: $3a^2b^3c^{-2}$

3. The amount of money, A , accrued at the end of n years when a certain amount, P , is invested at a compound annual rate, r , is given by $A = P(1+r)^n$. If a person invests \$310 in an account that pays 8% interest compounded annually, find the balance after 5 years.

Name: _____

ID: A

Find the sum.

4. $(2m^4 + 6m^2 - 6) + (-2m^2 + 5 + 6m^4)$

Find the difference.

5. $(9n^4 + 9n^2 + 8) - (4n^4 - 3n^2 + 2n - 2)$

Find the product.

6. $(7c + 5)(7c - 5)$

Factor the trinomial.

7. $5x^2 + 43x + 24$

Name: _____

ID: A

Solve the equation.

8. $x^2 - 5x - 14 = 0$

Solve the equation.

9. $16h^2 + 72h + 81 = 0$

- _____ 10. How would you change the graph of $y = x^2$ to produce the graph of $y = x^2 - 5$?
- a. shift the graph of $y = x^2$ right 5 units
 - b. shift the graph of $y = x^2$ down 5 units
 - c. shift the graph of $y = x^2$ up 5 units
 - d. shift the graph of $y = x^2$ left 5 units

Name: _____

ID: A

Graph the function.

11. $y = -9x^2$

Graph:

_____ 12. $y = 4x^2 + 5x + 4$

a.

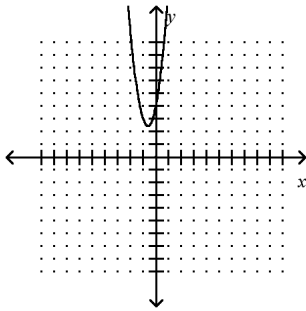

c.

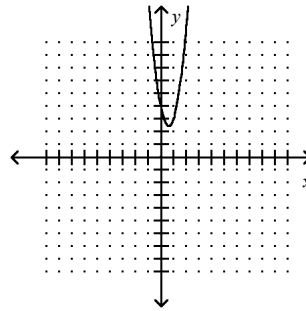

b.

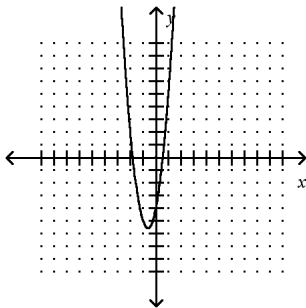

d.

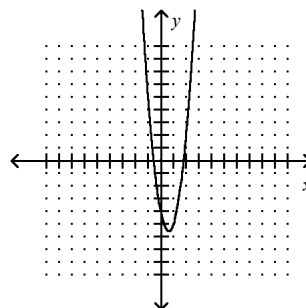

Name: _____

ID: A

13. $y = 2x^2 - 2x + 1$

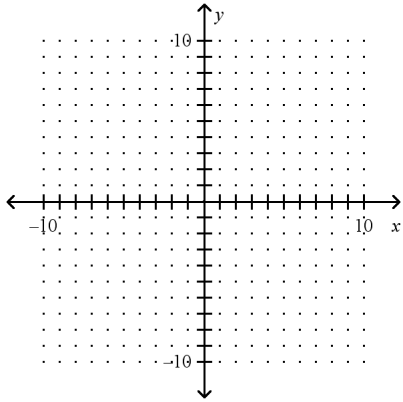

Solve the equation by graphing.

14. $x^2 - 5x + 4 = 0$

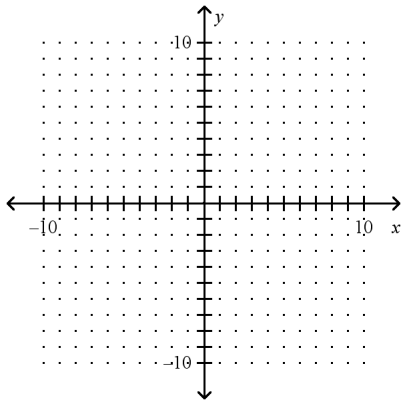

Name: _____

ID: A

Solve the equation by graphing, approximate your answers to the nearest tenth.

15. $x^2 - 3x + 1 = 0$

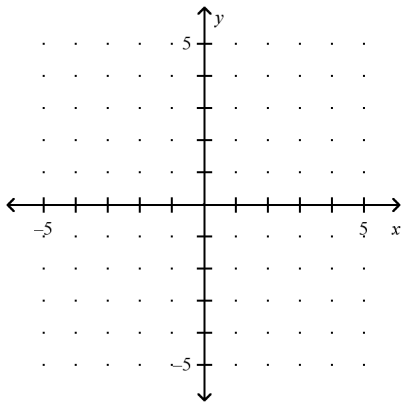

16. $x^2 - 4x - 5 = 0$

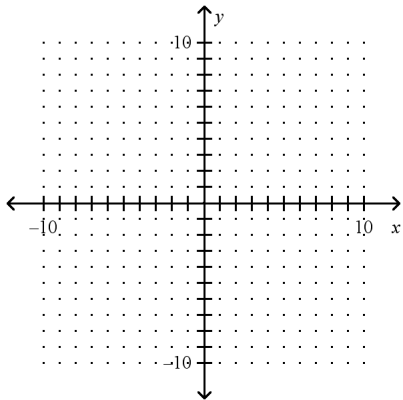

Name: _____

ID: A

Graph the following function, and determine the zeros, if there are any.

17. $f(x) = 3x^2 - 9x + 6$

Solve the quadratic equation.

_____ 18. $x^2 + 8x + 14 = 0$

a. $4 + \sqrt{2}, 4 - \sqrt{2}$

b. $-8 + 2\sqrt{2}, -8 - 2\sqrt{2}$

c. $8 + 2\sqrt{2}, 8 - 2\sqrt{2}$

d. $-4 + \sqrt{2}, -4 - \sqrt{2}$

Use the quadratic formula to solve the equation.

_____ 19. $x^2 = 15x - 34$

a. $\frac{15 - \sqrt{89}}{2}, \frac{15 + \sqrt{89}}{2}$

b. $-15 - \sqrt{89}, -15 + \sqrt{89}$

c. $15 - \sqrt{89}, 15 + \sqrt{89}$

d. $\frac{-15 - \sqrt{89}}{2}, \frac{-15 + \sqrt{89}}{2}$

Name: _____

ID: A

20. $x^2 + 7x + 7 = 0$

Use the quadratic formula to solve the equation. Round your solution to the nearest hundredth, if necessary.

21. $x^2 - x = 2$

22. $2x^2 - x = 1$

23. $x^2 - x = 6$

Algebra 1 Mastery Test #9 Review Answer Section

1. ANS:
(1, 3)

TOP: Lesson 6.3 Solve Linear Systems by Adding or Subtracting

2. ANS:
$$\frac{3a^2b^3}{c^2}$$

TOP: Lesson 7.3 Define and Use Zero and Negative Exponents

3. ANS:
\$455

TOP: Lesson 7.4 Write and Graph Exponential Growth Functions

4. ANS:
 $8m^4 + 4m^2 - 1$

TOP: Lesson 8.1 Add and Subtract Polynomials

5. ANS:
 $5n^4 + 12n^2 - 2n + 10$

TOP: Lesson 8.1 Add and Subtract Polynomials

6. ANS:
 $49c^2 - 25$

TOP: Lesson 8.3 Find Special Products of Polynomials

7. ANS:
 $(5x + 3)(x + 8)$

TOP: Lesson 8.6 Factor $ax^2 + bx + c$

8. ANS:
-2, 7

TOP: Lesson 8.5 Factor $x^2 + bx + c$

9. ANS:
 $h = -\frac{9}{4}$

TOP: Lesson 8.7 Factor Special Products

10. ANS: B TOP: Lesson 9.1 Graph $y = ax^2 + c$

11. ANS:

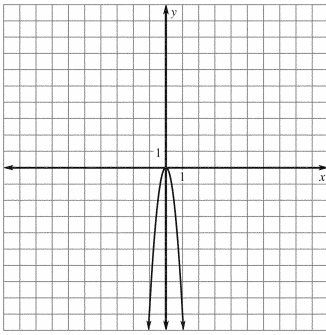

TOP: Lesson 9.1 Graph $y = ax^2 + c$

12. ANS: A

TOP: Lesson 9.2 Graph $y = ax^2 + bx + c$

13. ANS:

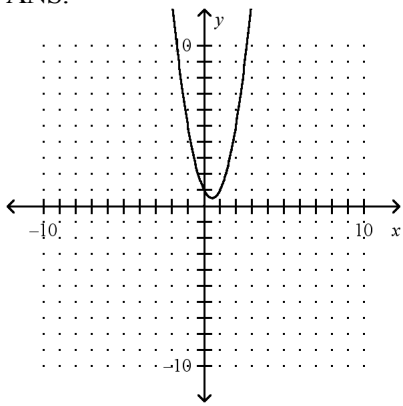

TOP: Lesson 9.2 Graph $y = ax^2 + bx + c$

14. ANS:

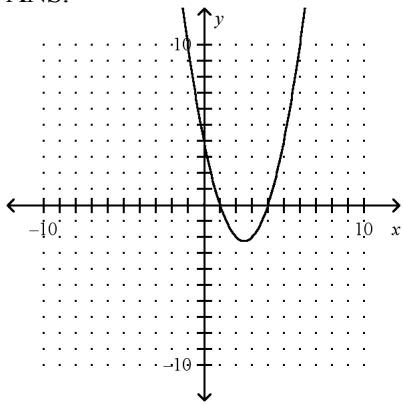

$$x = 1 \text{ and } x = 4$$

TOP: Lesson 9.3 Solve Quadratic Equations by Graphing

15. ANS:

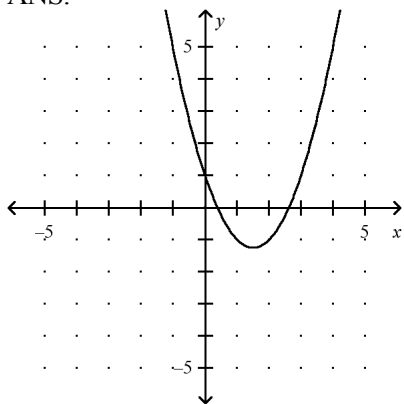

$x = 2.6$ and $x = 0.4$

TOP: Lesson 9.3 Solve Quadratic Equations by Graphing

16. ANS:

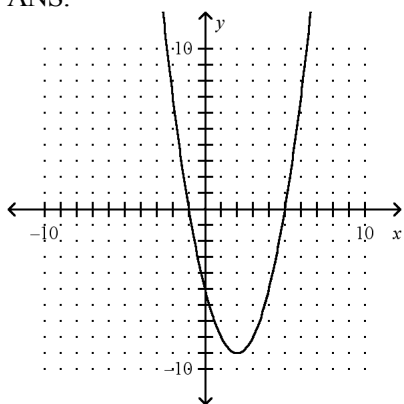

5, -1

TOP: Lesson 9.3 Solve Quadratic Equations by Graphing

17. ANS:

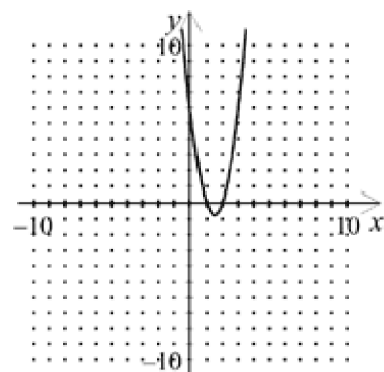

2, 1

TOP: Lesson 9.3 Solve Quadratic Equations by Graphing

18. ANS: D

TOP: Lesson 9.6 Solve Quadratic Equations by the Quadratic Formula

19. ANS: A

TOP: Lesson 9.6 Solve Quadratic Equations by the Quadratic Formula

20. ANS:

$$\frac{-7 - \sqrt{21}}{2}, \frac{-7 + \sqrt{21}}{2}$$

TOP: Lesson 9.6 Solve Quadratic Equations by the Quadratic Formula

21. ANS:

2, -1

TOP: Lesson 9.6 Solve Quadratic Equations by the Quadratic Formula

22. ANS:

$$1, -\frac{1}{2}$$

TOP: Lesson 9.6 Solve Quadratic Equations by the Quadratic Formula

23. ANS:

3, -2

TOP: Lesson 9.6 Solve Quadratic Equations by the Quadratic Formula